

QUALITY DATA SHEET

Customer **RZ-MARKET**
Product Description **CO-EXT PROFILE**

TANKAUÇUK

Material Control

Report Date: **28.02.2024**

1. EPDM Solid Compound

Part Nr **MPRAA25A1M0490**

Tests	Units	Limits
Density	Gr / cm ³	1,28-1,32
Hardness	Sho A	67-72
Tensile Strength	N / mm ²	Min 6,00
Elongation at breaking	%	Min 200

Catalog Nr **A1.003**

2. EPDM Sponge compound

Density	Gr / cm ³	0,70-0,90
Hardness	Sho 0	60-70
Tensile Strength	N / mm ²	Min: 2,00
Elongation at breaking	%	Min: 150

3. Reinforcement : Wire Reinforcement

Width	mm	21,80-22,10
Thickness	mm	0,74±0,02

Dimensional Control

C.Nr	Units	Limits
A	mm	9,5 +0,8 / -0,6
B	mm	7,5 +1 / -0,5
C	mm	3,6±0,4
D	mm	11±0,8
E	mm	1,5±0,35

Technical Drawing

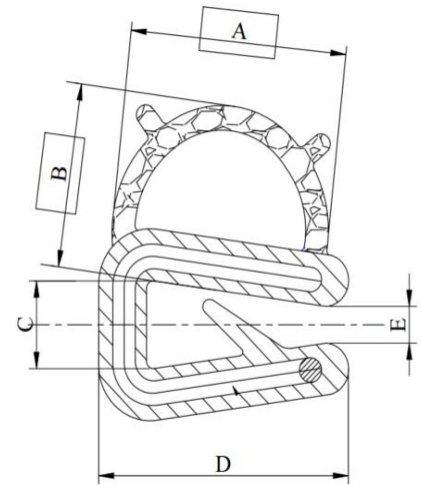

Note: Do not measure over Technical picture!

Final Result

OK

Prepared By

Quality Management System Responsible

Evrin Sezgin Özen

Approval by

Quality Manager

Ayşegül Tanık